

# Daniel Chapter Twelve

## Chapter Twelve Review...

### FINAL INSTRUCTIONS AND ANSWERS GIVEN TO DANIEL...

Daniel 12:4 “But you, Daniel, shut up the words and seal the book, until the time of the end. Many shall run to and fro, and knowledge shall increase.” (ESV)

**Perhaps what is meant is to stop writing, and secure what he has written; Compare this with Daniel 8:17,19,26;**

**Both visions (Daniel 8:10-12) were to be sealed up; Both pertained to many days in the future; Yet both visions were fulfilled at least initially within 200-400 years.**

# TERMS/VOCABULARY

**Eschatology**- the study of last things

**Millineum**- 1000-year reign of Christ on the earth (see Rev 20:2)

**Type (typical)**- used in scripture to refer to a person, place or thing that is representative or symbolical (ie. The tabernacle is a **type** of Christ)

**Antichrist**- some views hold this to be a specific person who will gain power at the end of the ages; some views hold this to be a “spirit” that can indwell many different individuals.

**Antitype (antitypical)**- used in scripture to refer to the fulfillment of a symbolic term (ie. Christ's sacrificial death is the **antitype** of the old testament sacrificial lambs).

# An Overview of Old Testament History

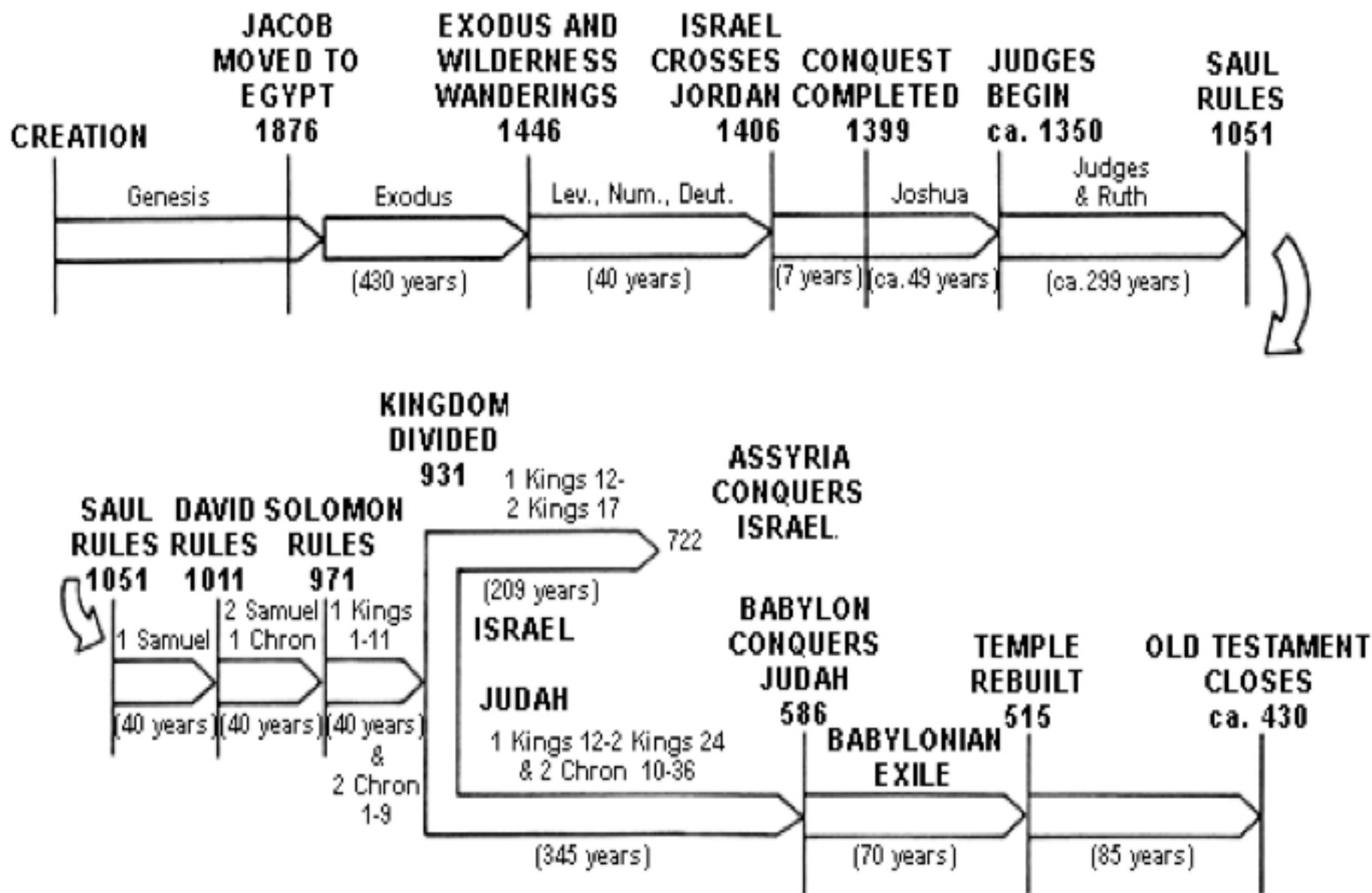

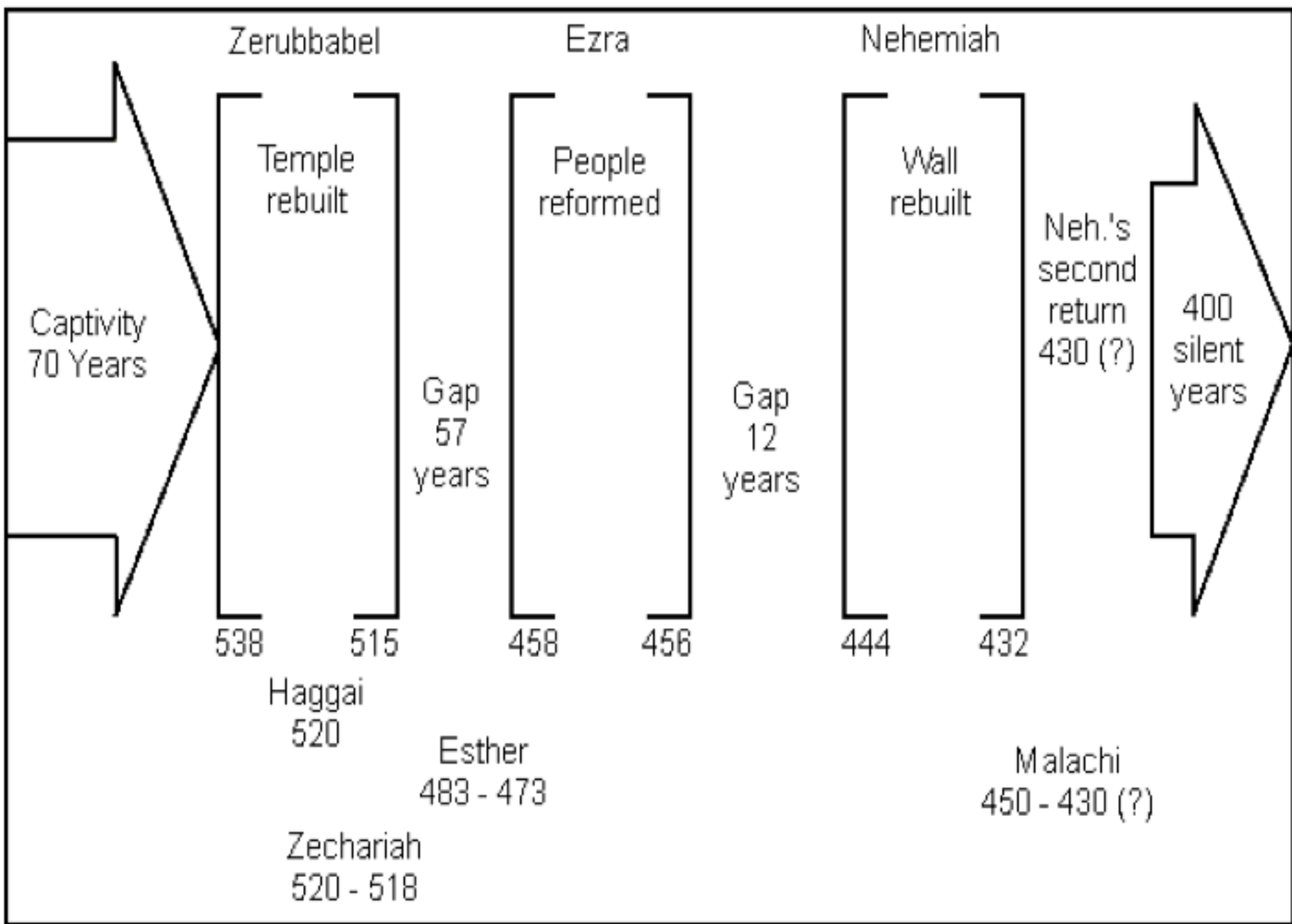

**The Three Returns from Exile**

# Daniel 2, 7-9, 11 & 12

2300 Evenings and Mornings / Prophetic Years (Dan 8)

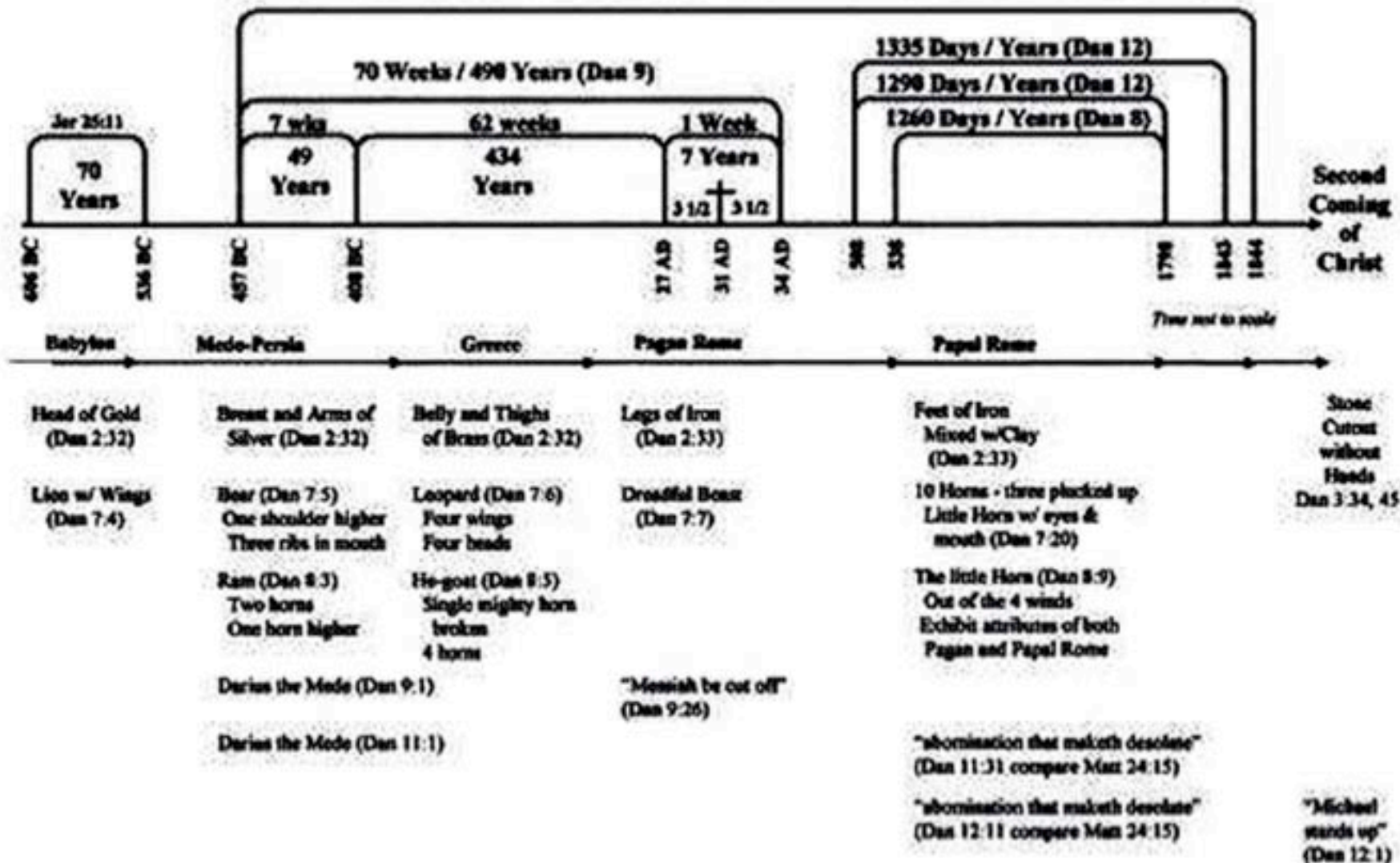

QUESTIONS And/or  
OBSERVATIONS



**“knowledge  
shall  
increase”**

**110,000,000 (MILLION) RESULTS (HITS)**

**That is, towards the end of the time appointed, many persons will be stirred up to inquire into these things delivered in this book, and will spare no pains or cost to get knowledge of them; will read and study the Scriptures, and meditate on them; compare one passage with another; spiritual things with spiritual, in order to obtain the mind of Christ; will peruse carefully the writings of such who have gone before them, who have**

**attempted anything of this kind; and will go far and near to converse with persons that have any understanding of such things: and by such means, with the blessing of God upon them, the knowledge of this book of prophecy will be increased; (JOHN GILL)**

## **The Book of Daniel Chapter 12b Lesson 20**

**Daniel 12:5-13 “Then I, Daniel, looked, and behold, two others stood, one on this bank of the stream and one on that bank of the stream. And someone said to the man clothed**

**in linen, who was above the waters of the stream, “How long shall it be till the end of these wonders?” And I heard the man clothed in linen, who was above the waters of the stream; he raised his right hand and his left hand toward heaven and swore by him who lives forever that it would be for a time, times, and half a time, and that when the shattering of the power of the holy people comes to an end all these things would be finished. I heard, but I did not understand. Then I said, “O my lord, what shall be the outcome of these things?” He said, “Go your way, Daniel, for the words are shut up and sealed until the time of the end.**

**Many shall purify themselves and make themselves white and be refined, but the wicked shall act wickedly. And none of the wicked shall understand, but those who are wise shall understand. And from the time that the regular burnt offering is taken away and the abomination that makes desolate is set up, there shall be 1,290 days. Blessed is he who waits and arrives at the 1,335 days. But go your way till the end. And you shall rest and shall stand in your allotted place at the end of the days.” (ESV)**

## Two final questions answered:

**A. One question overheard by Daniel –  
Daniel 12:5-7;**

**1) Daniel saw two others, beside the ONE who had been speaking to him, on each side of the river bank.**

**2) One asked the man clothed in linen above the river: "How long shall the fulfillment of these wonders be?"**

**3) The answer:** "...a time, times, and half a time; and when the power of the holy people has been completely shattered, all these things shall be finished."

**a) The "time, times, and half a time" (3 and a half years, 42 months, 1260 days) is commonly used to describe a definite, marked, period of tribulation - cf. Daniel 7:25; Revelation 11:2,3; 12:6,13,14; 13:5;**

**Daniel 7:25** “He shall speak words against the Most High, and shall wear out the saints of the Most High, and shall think to change the times and the law; and they shall be given into his hand for a time, times, and half a time.”

**Revelation 11:2,3** “but do not measure the court outside the temple; leave that out, for it is given over to the nations, and they will trample the holy city for forty-two months. And I will grant authority to my two witnesses, and they will prophesy for 1,260



days, clothed in sackcloth.

**Revelation 12:6; “and the woman fled into the wilderness, where she has a place prepared by God, in which she is to be nourished for 1,260 days.”**

**Revelation 12:13-14 “And when the dragon saw that he had been thrown down to the earth, he pursued the woman who had given birth to the male child. But the woman was given the two wings of the great eagle so that she might fly from the serpent into the**

wilderness, to the place where she is to be nourished for a time, and times, and half a time.”

**Numerous uses of the specific time period of 3 ½.**

**b) When the persecution has accomplished its purpose, then the things described will take place.**

**B. The question asked by Daniel -**

**Daniel 12:8-13** “I heard, but I did not understand. Then I said, “O my lord, what shall be the outcome of these things?” He said, “Go your way, Daniel, for the words are shut up and sealed until the time of the end. Many shall purify themselves and make themselves white and be refined, but the wicked shall act wickedly. And none of the wicked shall understand, but those who are wise shall understand. And from the time that the regular burnt offering is taken away and the abomination that makes desolate is set up,

**there shall be 1,290 days. Blessed is he who waits and arrives at the 1,335 days. But go your way till the end. And you shall rest and shall stand in your allotted place at the end of the days.” (ESV)**

**1) Not understanding, Daniel asks: "...what shall be the end of these things?"**

**2) Daniel is first told:**

**“To go, (**back to work**) for the words are closed and sealed till the time of the end, that many shall be purified, and the wise shall understand - that the wicked shall do wickedly, and not understand” -**

**That there will be a period of "1290 days" beginning from: The time the daily sacrifice is taken away – and the abomination of desolation is set up - those who wait and come to "1335 days" will be blessed -- whether literal or figurative, these numbered days appear to apply to the period of the Antiochian persecution (ca. 168 B.C.)**

**3) Daniel is then told:**

**a) To go his way till the end...**

**b) For he shall rest and arise to his inheritance at the end of the days --**

**This "end" or "end of the days" may refer to the actual resurrection on the day of Judgment, not "the time of the end" spoken of throughout this vision.**

Three and a half is the time of the world power, in which the earthly kingdoms rule over the heavenly [AUBERLEN]. "Three and a half" represents *the idea of spiritual trial*; (besides this certain *symbolical* meaning, there is doubtless an accurate *chronological* meaning, which is as yet to us uncertain):

It is half of "seven," the complete number, so a semi-perfect state, one of probation.

The holy city is trodden by the Gentiles forty-two months (Revelation 11:2), so the exercise of the power of the beast (Revelation 13:5).

**Also the two witnesses preach in sackcloth 1260 days, and remained unburied three days and a half: so the woman in the wilderness: also the same for a "time, times, and a half" (Revelation 11:3,9;12:6,14).**

**The famine and drought on Israel in Elijah's days were for "three years and six months" (Luke 4:25; James 5:17); the same period as Antiochus' persecution: so the ministry of the Man of Sorrows, which ceased in the midst of a week (Daniel 9:27) [WORDSWORTH, *Apocalypse*]. JFB**



**1 Corinthians 2:14-15** “The natural person does not accept the things of the Spirit of God, for they are folly to him, and he is not able to understand them because they are spiritually discerned. The spiritual person judges all things, but is himself to be judged by no one.” **(ESV)**

## CONCLUSION

**Romans 15:4 “For whatever was written in former days was written for our instruction, that through endurance and through the encouragement of the Scriptures we might have hope.”(ESV)**

QUESTIONS And/or  
OBSERVATIONS

# Prayer Time





